

	Fresh Water	Pool Water	Sea Water	220-240 V	400 V	110-120 V	50 Hz	60 Hz	12 V AC	24 V DC	DMX	DMX/RDM	Plug and Spray
AquaAir 250	✓	✓	✓	✓	✓	✓	✓	✓	✓	✓	✓	✓	✓
AquaAir 250 / A	✓	✓	✓	✓	✓	✓	✓	✓	✓	✓	✓	✓	✓

AQUAAIR 250 / AQUAAIR 250/A

Oxygen plays a crucial role in breaking down nutrients in water. Many of the problems associated with an artificial lake or pond, such as algae infestation, silt or odour nuisance can be attributed to oxygen deficits. Missing oxygen can be fed into the body of water through specific water movement that introduces air. This stabilises a body of water's biological power of regeneration and results in optimal quality of the artificial lake or pond.

Product characteristics at a glance

- Suitable for pond surfaces up to 250 m²
- Adjustable injector nozzle for optimal oxygen input with depth penetration to 4 m
- High turnover rate bring standing water into life
- Extremely long service life thanks to high-quality workmanship and stainless steel elements
- Low noise underwater operation
- Fastening material included in the scope of delivery
- Optimal oxygen supply thanks to small bubbles

Ideal supplements to this product are BioKick and SediFree. Information on each of these products are found on pages 226 and 227.

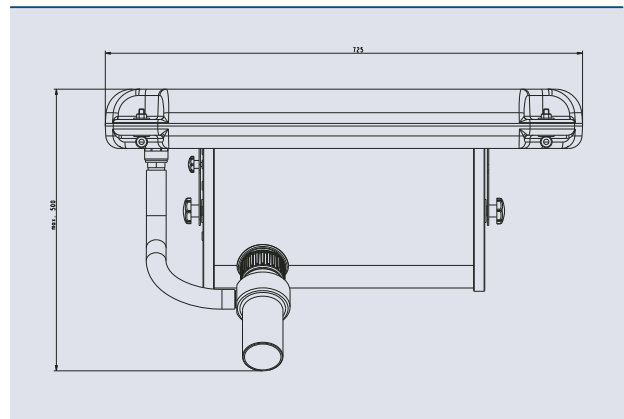



Injector nozzle
Adjustable injector nozzle for focussed oxygen input to aerate the pond.

Professional oxygen supply
Powerful pump with professional Venturi principle enables optimal oxygen supply in small bubbles.

Stainless steel basket
High quality design with corrosion-resistant filter basket and suspension element.

Fastening material
Easy and secure anchoring of the aerator thanks to the fastening material included in the scope of delivery. (2 x 20 meter, 3 mm thick)

Before: Standing water with excessive algae formation



After: Uniform oxygen enrichment plus circulation



The Aqua Air 250 is a floating aerator that provides an adequate supply of oxygen for bodies of water up to 250,000 litres. A pump supplies the air/water mixture to the artificial pond or lake via the venturi principle. The high volume flow guarantees air supply in the entire body of water through strong flow movements. Deep zones as well as shallow water zones can be optimally supplied with oxygen through the adjustable angle of the flow injector.

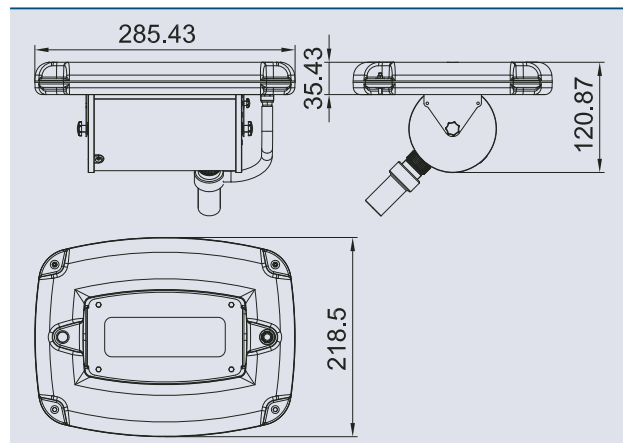

AquaAir	250	AquaAir	250 / A
Dimensions (L x W x H)	[mm] 725 x 555 x 310	Dimensions (L x W x H)	[inch] 29 x 22 x 12
Rated voltage	[V/Hz] 230 / 50	Rated voltage	[V/Hz] 110-120 / 60
Power consumption (Pump)	[W] 650	Power consumption (Pump)	[W/A] 700 / 5.8
Flow rate max.	[l/h] 30000	Flow rate max.	[ghp max] 7000
Air displacement quantity	[l/h] ca. 8500	Air displacement quantity	[ghp max] 2500
Radiation depth	[m*] up to 4.0	Radiation depth	[ft*] up to 13
Filter surface intake	[cm²] ca. 3000	Filter surface intake	[sq.inch] approx. 465
For bodies of water to max.	[m³] 250	For bodies of water to max.	[gal] 65000
Minimum water depth	[m] 0.5	Minimum water depth	[inch] 20
Cable length	[m] 30.0	Cable length	[ft] 75
Weight	[kg] 28.0	Weight	[lbs] 66
Order no.	57479		57487

* Depends on the jet angle set